



Portable Staging User Guide

Components:

Putting together your smart stage system was designed to be simple enough for anyone to do easily. Nonetheless, let's take a moment for a little meet and greet...



A.) Platform

Durable, modular stage surface – supports up to 185 lbs./sq. ft. (900kg/sq. meter).

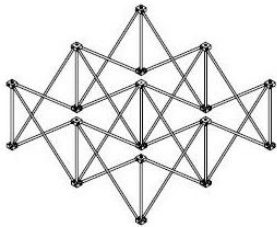

B) Riser

Supports platform surface - available in 8", 16", 24" and 32" (20, 30, 40 & 60 cm.) heights.

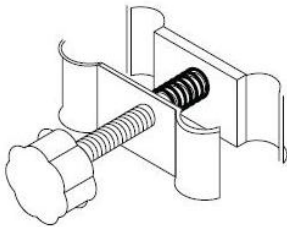

C) Riser Clamp

Provides support in situations where you would like to secure risers of different heights. Device is also used to secure steps to each other, as well as to risers.

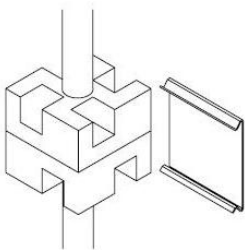

D) Riser Coupler

Allows you to extend the height of your platform by coupling a pair of existing risers. Caution: For safety reasons, do not couple more than 2 levels of risers

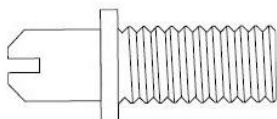

E) Coupling Post

Used when coupling one riser on top of another for added height. Adds additional support and stability.



F) Hex Key

Probably the only tool other than a screwdriver you'll need to put your stage system together.

Getting your stage system up and running has never been easier than this. You are just minutes away from having a sturdy, professional stage.

A) Stage Assembly:

- 1) Unpack your platform and risers.
- 2) If attaching guard Rails, see section **D) Guard Rail Assembly**, step 1
- 3) Expand riser completely
- 4) Align corner locking posts on riser with corner holes on platform
- 5) Lock platform to riser by turning the locking screws clockwise with the included hex key until tightly secured.
- 6) To assemble steps, follow the same procedure.

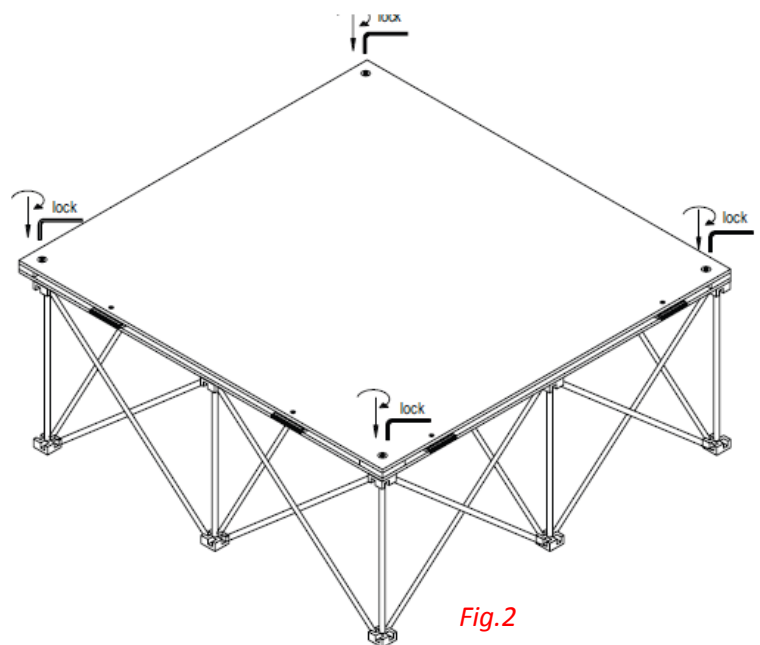
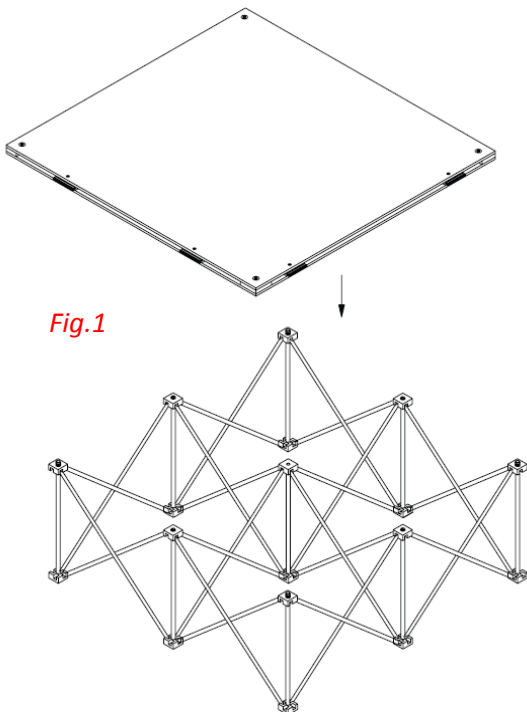
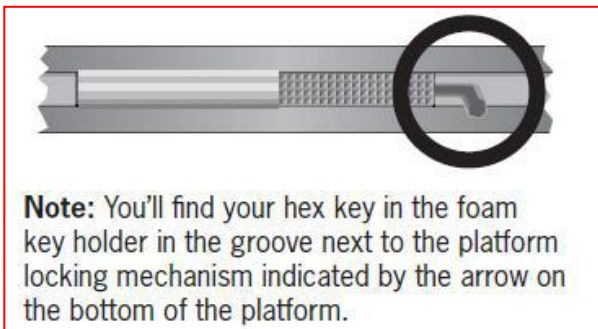

B) Securing Platforms:

- 1) Expand risers completely and attach platforms as described in **Stage Assembly**.
- 2) Make sure that the platforms' interlocking devices are in the closed position.
- 3) Insert male locking mechanism into groove on opposite platform and rotate locking screw clockwise with the included hex key.
- 4) Repeat until your stage system is complete.

Fig.1

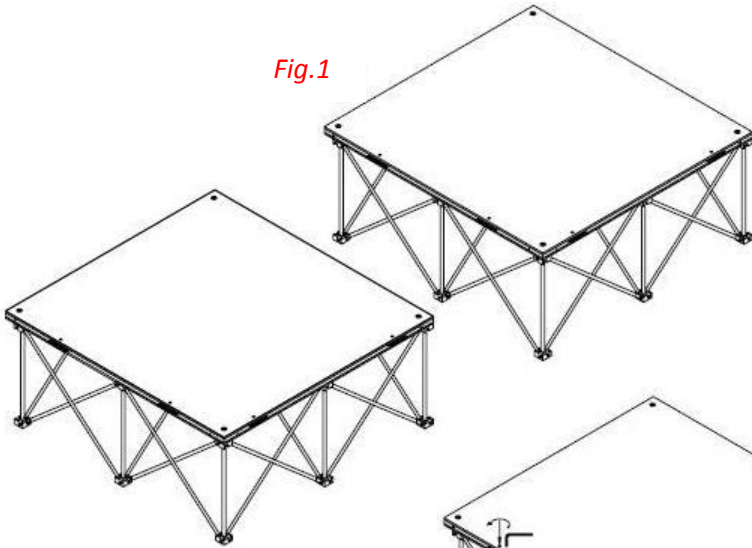

Fig.2

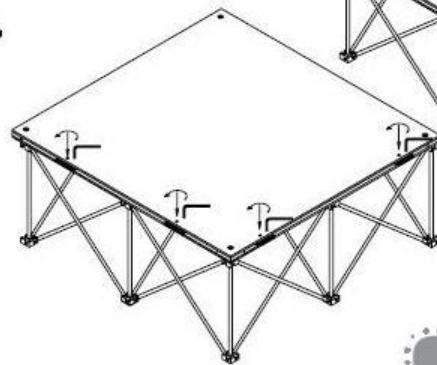
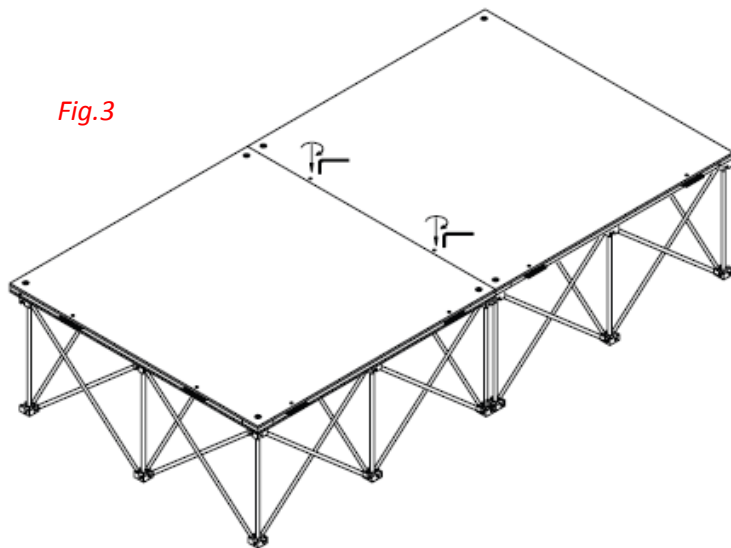

Fig.3



A Close-Up Look:



A.) Align Platforms

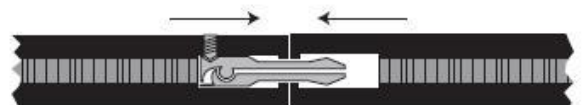

B.) Insert male locking mechanism

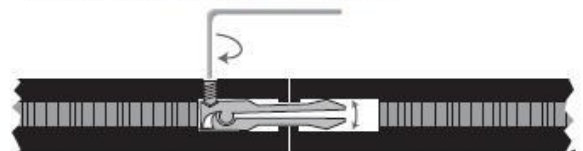

C.) Rotate locking screw clockwise

C) Securing Steps or Risers of Different Heights:

When designing a custom stage configuration, you may encounter situations where you would like to use risers of different heights. Because the platforms' interlocking mechanism will not work in this scenario, we've designed an alternate method that provides the same level of security. This is the same procedure that would use when securing steps both to each other and to the stage risers.

- 1) Expand and align risers. Mount stage platforms as described in **Stage Assembly**.
- 2) If necessary, loosen clamp by turning knob counter-clockwise. Insert clamp between risers and rotate entire clamp in either direction until aligned properly. (*Fig. 3*)

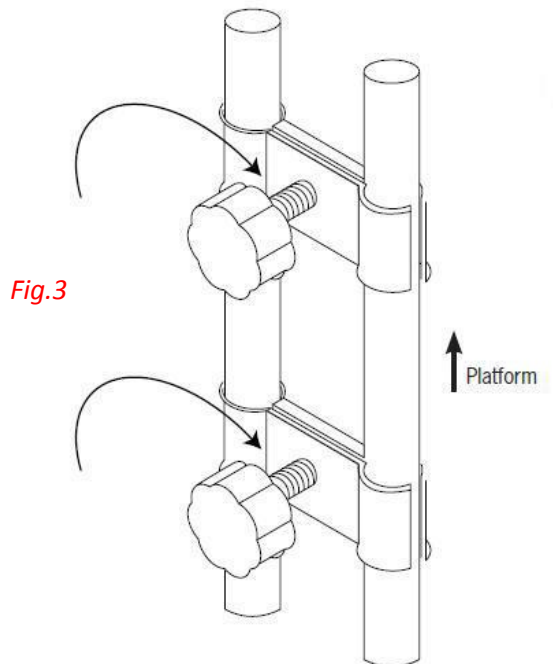
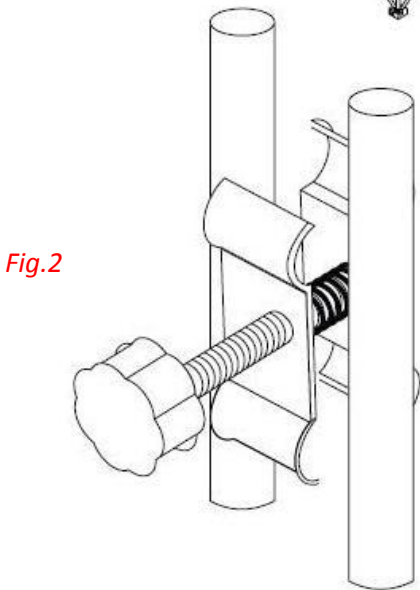
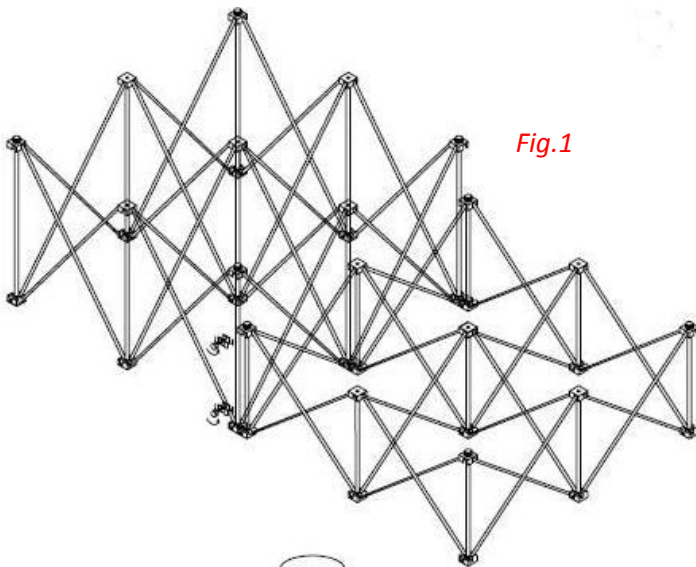

D) Stage Riser Coupling

Coupling together two risers allows you to extend the height of your platforms.

Caution: For safety reasons, do not couple more than 2 levels of risers.

- 1) Expand and both risers completely.
- 2) On bottom riser, remove corner locking posts and replace with bronze coupling posts.
- 3) Align coupling posts with holes on bottom of top riser feet.
- 4) Secure silver stabilizing brackets as illustrated in *Fig. 4*.
- 5) Mount stage as described in *Stage Assembly*.

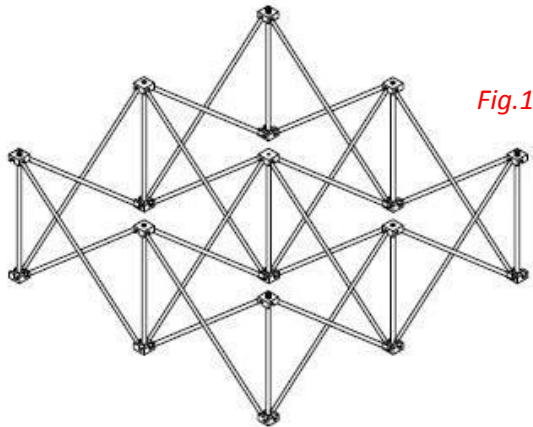

Fig.1

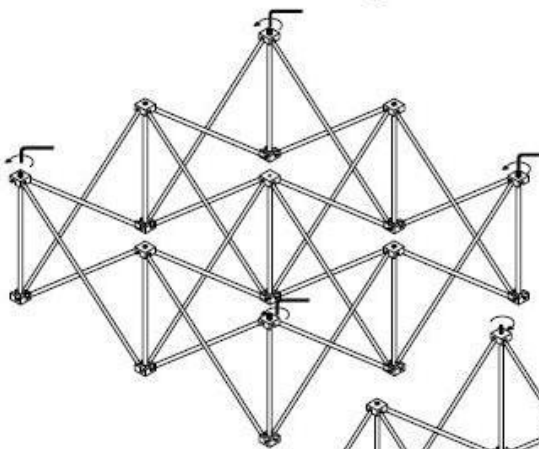

Fig.2

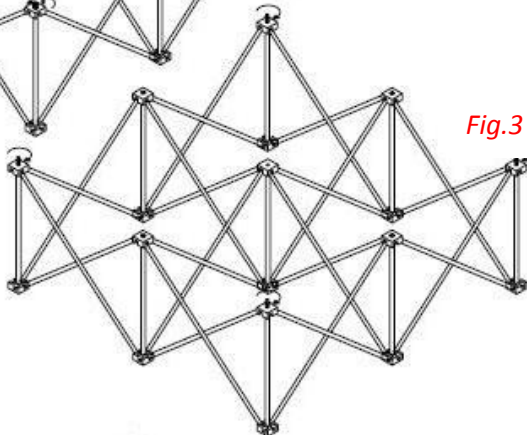
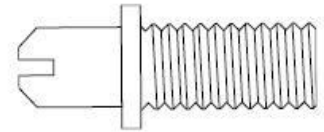
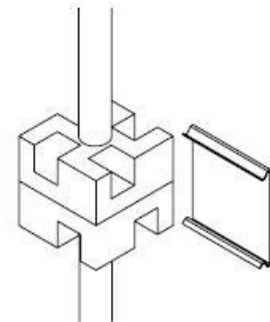

Fig.3

What You'll Need:



Coupling Post



Riser Coupler

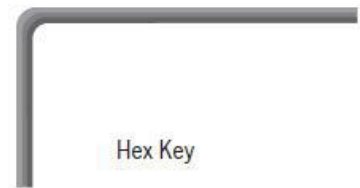

Hex Key

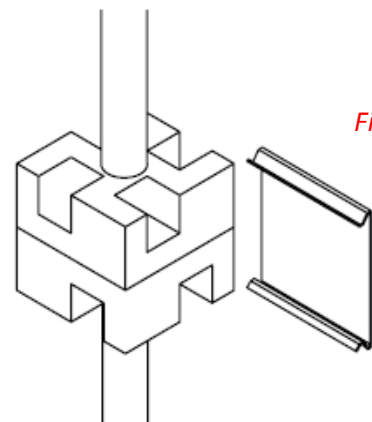
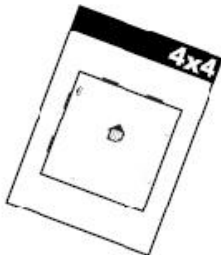

Fig.4

D) Guard Rail Assembly:

- 1) Drill through the marked guide holes as indicated in *Fig.1* using a 7/16" or 11mm drill bit. Be sure to only drill the holes required for your configuration and hold drill perpendicular to the platform while drilling.
- 2) Assemble and connect all platforms, risers, and steps according to the above steps.
- 3) Align guard rail with holes and slide rail onto platform.
- 4) Secure guard rail with bolt and large hex key as shown in *Fig 2-3*. Secure all guard rails to platforms before continuing.
- 5) Connect guard rails to each other using guard rail side to side mounting hardware and a small hex key. Connect guard rails to each other at corners using the guard rail corner mounting hardware. *Fig 4*
- 6) Assemble stair hand rails following the same procedure.

What You'll Need:



Hole Templates (pgs 10-13)



Ruler & Writing Instrument



Power Drill

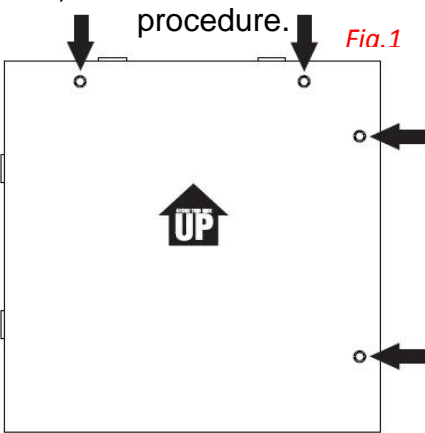

Fig.1

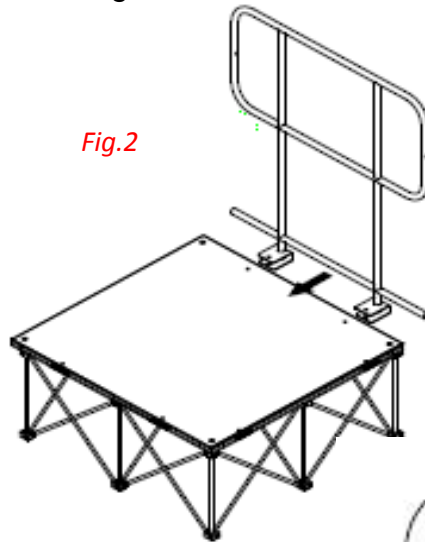

Fig.2

Fig.3

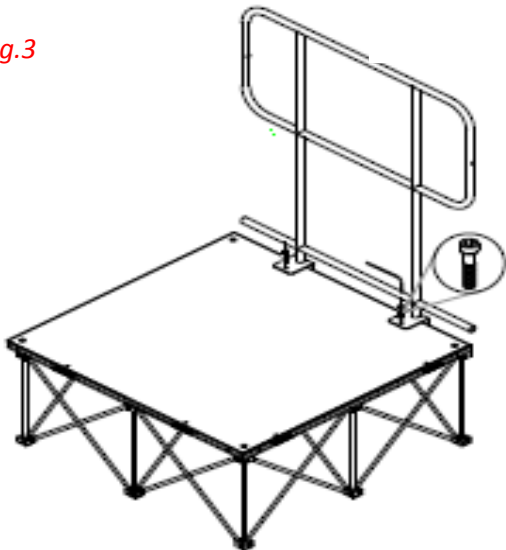
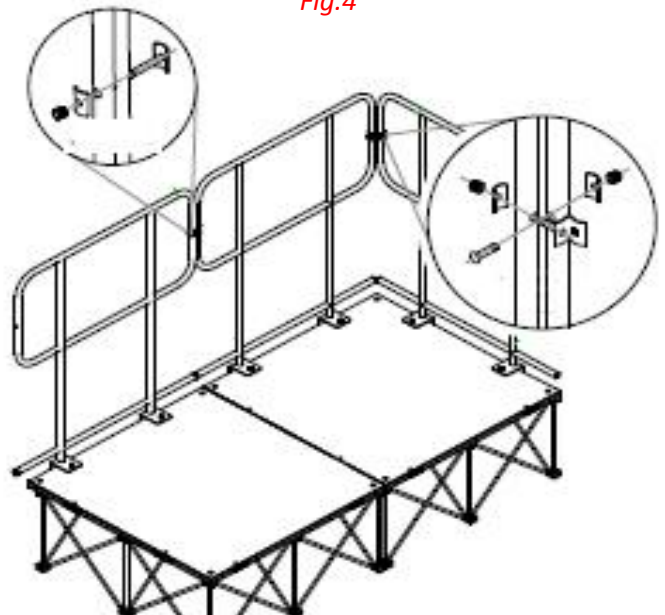

Fig.4



Signature Systems Group, LLC.

50 East 42nd Street, 14th Floor • New York, NY 10017

Tel 212-953-1116 • Fax 212-953-1117 • Toll Free 800-709-8151

www.expressdeckstaging.com www.alphadeckstaging.com www.eventdeck.com